

Neil Kidby Austin 3 Litre Specialist

www.austinthreelitres.co.uk

E-mail neil@austinthreelitres.co.uk

There have been cases of Austin 3-Litres failing mot tests incorrectly on steering rack wear at the column pinion area. The steering rack fitted to these cars was made by a company called Camgears, and is fitted with a load sensing spool valve. This spool valve is controlled by a reaction to the load created by the tyre load in relation to the road surface. The greater the load, i.e. at rest, the greater the sideways reaction on the steering column shaft and thus the spool valve is opened further giving more oil pressure to the rack, and so more assistance. As the vehicle speed increases, the tyre load in relation to the surface decreases and so the column does not have as much sideways movement to the valve, and so less oil pressure and therefore less assistance is delivered. The diagram below shows oil flow details. My professional qualifications are;

I.M.I (Institute of the Motor Industry)

A.M.S.O.E (Associate Member of Society of Operation Engineers)

A.M.I.R.T.E (Associate Member of the Institute of Road Transport Engineers)

Eng-Tech (Registered Technical Engineer)

I.V.R (Institute of Vehicle Recovery)

If I can be of any further assistance please do not hesitate to get in touch. Kind regards Neil Kidby

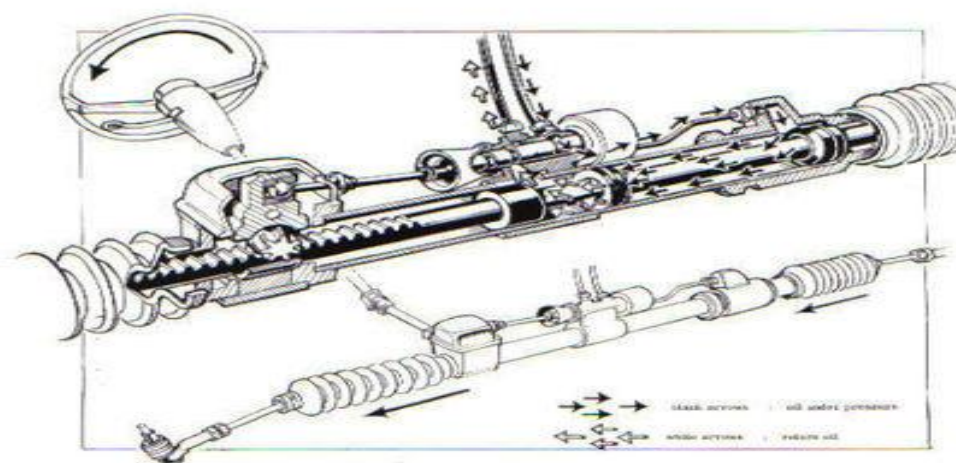

 **AUSTIN**

Power Steering for
Austin 3-Litre De-luxe

Negative No. 196279
Copyright Free
Public Relations Office
Langford Rd., Birmingham
Telephone 023-475 2383